

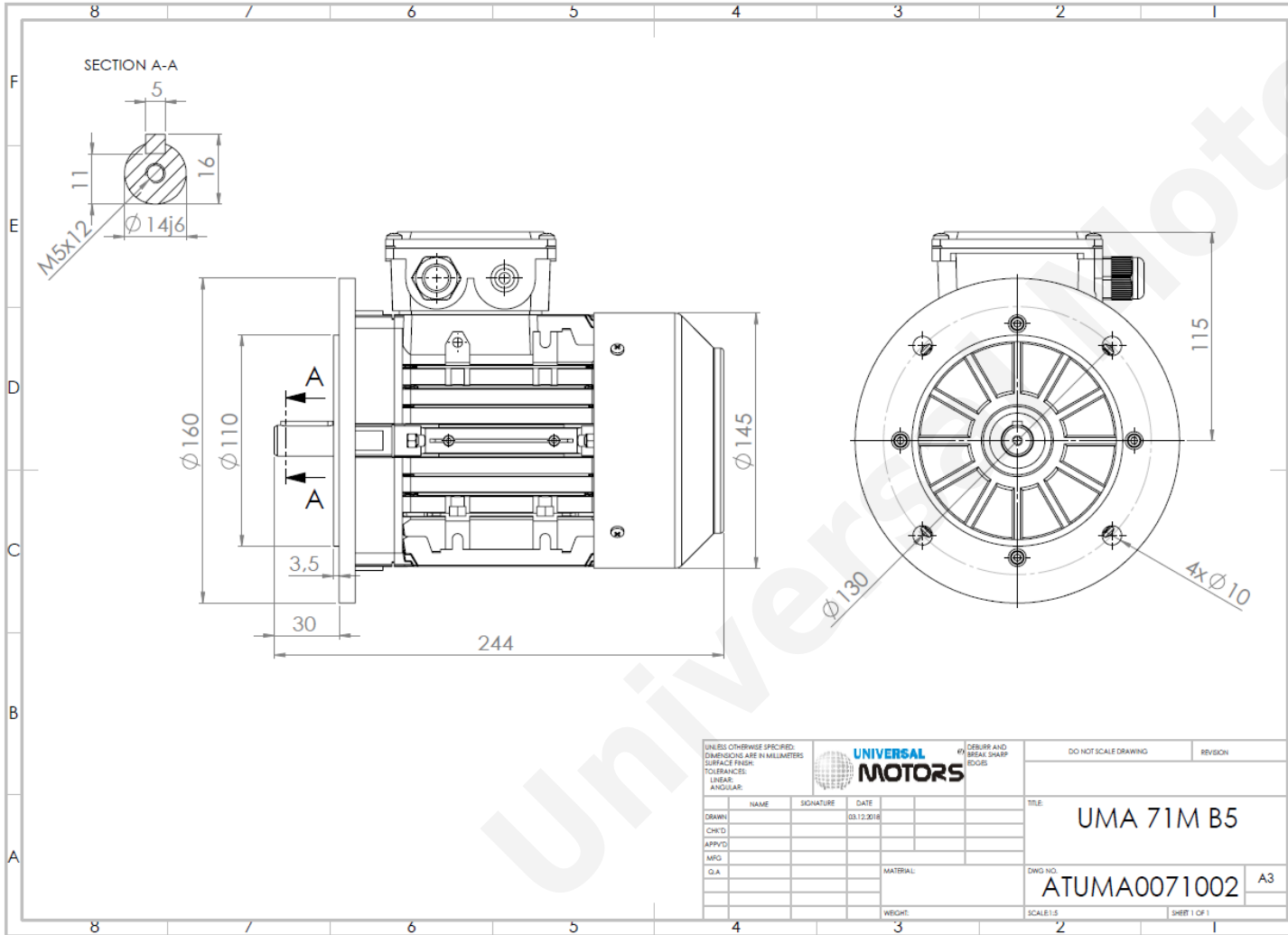

TECHNICAL DATA

Three Phase Electric Motors - Aluminum Frame
 UM2A 71M2-4
 0.37 kW / 0.50 Cv
 1400 RPM



Motor type:	UM2A 71M2-4
Output:	0.37 kW / 0.50 Cv
Speed (min ⁻¹):	1400 RPM
Frequency:	50 Hz
Voltage:	400 V
Current:	1.01 A
Power factor (Cos Ø):	0.73
Poles:	4
Insulation class:	F
Temperature rise Class:	B
Efficiency 50%:	69.2 %
Efficiency 75%:	73.0 %
Efficiency 100%:	72.7 %
Torque:	2.55 N.m
Tstarting/Tnominal:	2.4
Istarting/Inominal:	4.7
Tmaximum/Tnominal:	2.5
Noise:	55 Db(A)
Weight:	6.3 Kg
Brake AC:	AC2
Torque Brake DC:	4 N.m
Bearing DE:	6202 2Z
Bearing NDE:	6202 2Z
Torque Brake AC:	15 N.m
Brake DC:	REB-05-06

Regime - S1

Altitude - 1000m

Environment Temperature - 40°C

CONTACTS:

UNIVERSAL MOTORS Tel: +351 252 299 080
 Rua de São Brás,745 Fax: +351 252 299 089
 4480-782 VILA DO CONDE Mail: geral@universalmotors.pt

* References applied only in the UK